

Digital Stepper Drive CS3M683

1. Introduction

Descriptions

The CS3M683 is a new generation digital 3-phase stepper motor driver, based on a 32-bit DSP processor, combination of the anti-resonance, low noise, micro-step and low temperature rise technology significantly improve the performance of the stepper motor, has low noise, small vibration, low temperature rise and high-speed torque. The driver use online adaptive PID technology, without manual adjustment can be automatically generated optimal parameters for different motors, and achieve the best performance.

Supply voltage range from 24VDC to 60VDC, suitable for driving various 3-phase hybrid stepping motors which phase current below 8.3A. The microstep can be set from full step to 40000steps/rev and the output current can be set form 3.2A to 8.3A; with automatic idle-current reduction, self-test, overvoltage, under-voltage and over-current protection.

Features

- High-performance, low price
- micro-step
- Automatic idle-current reduction
- Optical isolating signals I/O
- Max response frequency up to 200Kpps
- Low temperature rise, smooth motion
- Online adaptive PID technology

Applications

Suitable for a variety of large-scale automation equipments and instruments. For example: labeling machine, cutting machine, packaging machine, plotter, engraving machine, CNC machine tools and so on. It always performs well when applied for equipment which requires for low-vibration, low-noise, high-precision and high-velocity.

Electrical Specifications

Parameter	Min	Typical	Max	Unit
Input Voltage(DC)	20	-	60	VDC
Output current	0	-	8.3	A
Pulse Signal Frequency	0	-	200	KHZ
Logic Signal Current	7	10	16	MA

2.Current and microstep Setting

Current setting

Peak	RMS	SW1	SW2	SW3
Default		off	off	off
3.2A	2.3A	on	off	off
4.0A	2.9A	off	on	off
4.9A	3.5A	on	on	off
5.7A	4.1A	off	off	on
6.4A	4.6A	on	off	on
7.3A	5.2A	off	on	on
8.3A	5.9A	on	on	on

Standstill Current Setting

SW4 is used for standstill current setting. OFF meaning that the standstill current is half of the dynamic current; and ON meaning that standstill current is the same as the selected dynamic current. Usually the SW4 is set to OFF, in order to reduce the heat of the motor and driver.

Microstep Setting

Step/Rev	SW5	SW6	SW7	SW8
Default	on	on	on	on
400	off	on	on	on
800	on	off	on	on
1600	off	off	on	on
3200	on	on	off	on
6400	off	on	off	on
12800	on	off	off	on
25600	off	off	off	on
1000	on	on	on	off
2000	off	on	on	off
4000	on	off	on	off
5000	off	off	on	off
8000	on	on	off	off
10000	off	on	off	off
20000	on	off	off	off
40000	off	off	off	off

3. Connectors and Pin Assignment

Control signal Connector

Control Signal connector	
Name	Description
PUL+	Pulse signal positive
PUL-	Pulse signal negative
DIR+	Direction signal positive
DIR-	Direction signal negative
ENA+	Enable signal positive, usually left unconnected(enable)
ENA-	Enable signal negative, usually left unconnected(enable)

Power and Motor Connector

GND	Power supply, +24~+90VAC or 20~60 VAC
+VDC	
U	Motor phase U

V	Motor phase V
W	Motor phase W

Control Signal Connector Interface

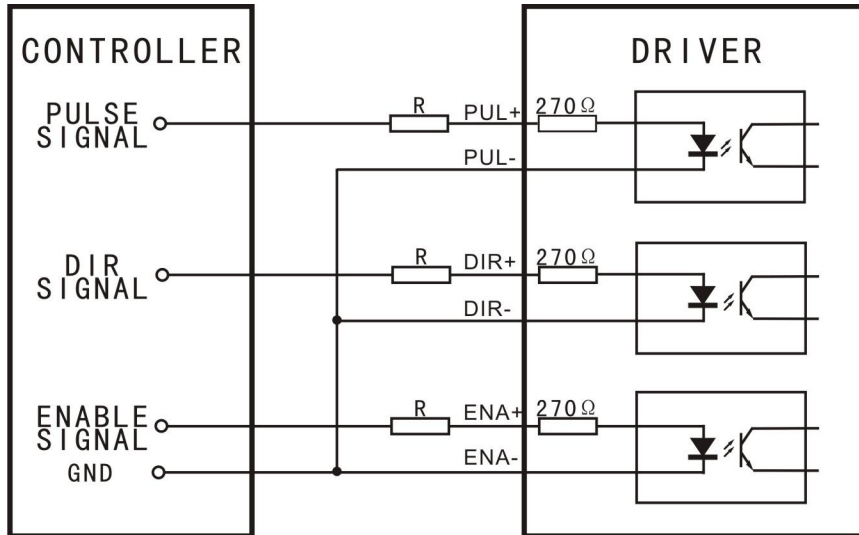

Figure1: Common-Cathode

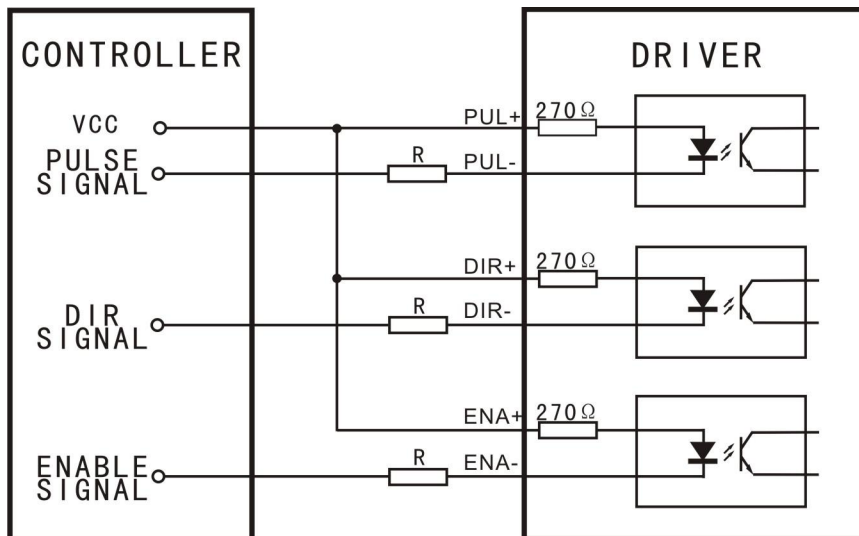

Figure2: Common-Anode

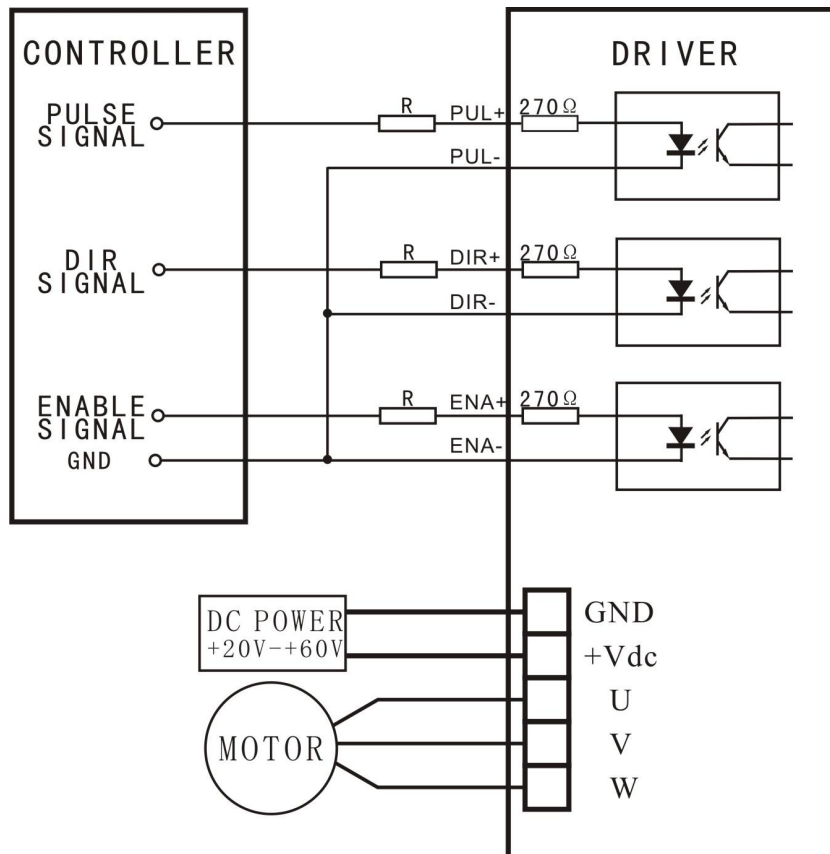

Figure 3: Typical connection

VCC	R
5V	0
12V	680Ω
24V	1.8KΩ

Table1

4. Problems and Solutions

problems	Possible cause	solutions
Motor is not rotating	No power supply	Check the power supply
	No control signal	Check the control signal
	The driver is disabled	Don't connected the enable signal or enable the driver
ALM lights	Supply voltage is too high or too low	Check the supply voltage
	Motor line short-circuit	Check motor lines eliminate the short-circuit
	Motor line wrong connect	Check the motor wiring
	Motor or drive failure	Replace the motor or drive
Motor rotates in the wrong direction	Motor phases connected in reverse	Reverse the phases line
	Motor line break	Change the phases are connected
Inaccurate Position	The Micro steps set incorrectly.	Set the correct segments
	The motor load is too heavy.	Increasing the current
	Control signal is interfered	Eliminate interference
Motor Stalled	Power supply voltage too low	Increasing the supply voltage
	Accelerating time is too short.	Extend the acceleration time
	Current setting is too small	Increasing the current
	Motor torque is too small	Replace the motor

5. Mechanical Specifications (unit: mm(inch), 1 inch = 25.4mm)

